



viva-manipulacni-technika.cz



PRODEJ



SERVIS



BAZAR



PŮJČOVNA



VIVA - manipulační technika s.r.o.  
Terezínská 86, 410 02 LOVOSICE



viva-manipulacni-technika.cz

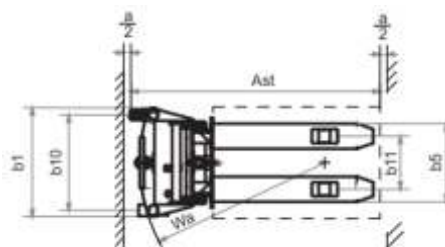
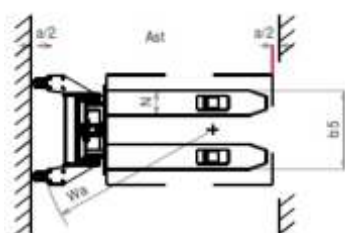
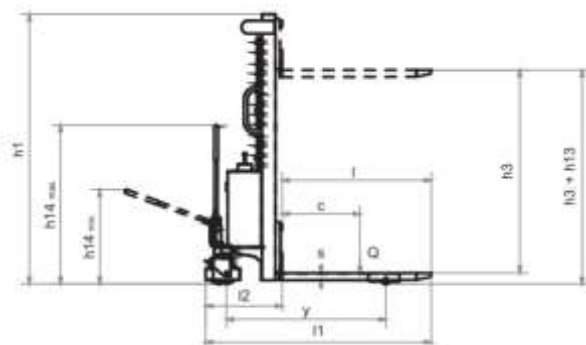
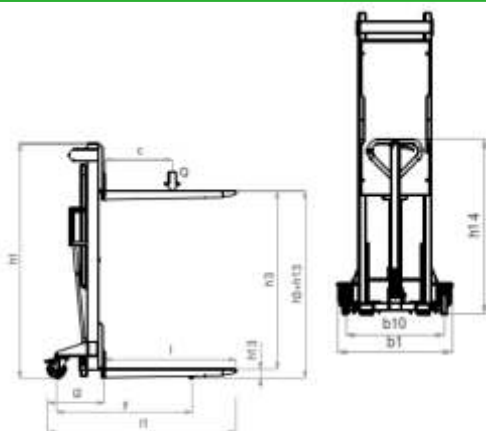

Pos.	Mod. EMS-10	
Q	t	1.0
c	mm	600
l	mm	1.150
l1	mm	1.660
y	mm	1.195
l2	mm	510
b1	mm	780
b10	mm	670
b5	mm	560
N	mm	180
h3	mm	1.560
h1	mm	2.073
h13	mm	90
h14 min/max	mm	671/1.170
a	mm	100
Wa	mm	1.262
Ast	mm	1.703
Weight	kg	220

Characteristics	1.1 Manufacturer		Italiana Carrelli Elevatori srl		
	1.2 Model		ESE-10		
	1.3 Drive		Manual		
	1.4 Operator type		Pedestrian		
	1.5 Load capacity / rated load	Q	t	1	
	1.6 Load centre distance	c	mm	600	
	1.9 Wheelbase	y	mm	1.230	
Weights	2.1 Service weight incl. battery (see line 6.5)		kg	320 380	
	2.2 Weight on axle with load, front/rear		kg	370 / 950 400 / 980	
	2.3 Weight on axle without load, front/rear		kg	200 / 120 230 / 150	
Wheels Chassis	3.1 Tires		polyurethane		
	3.2 Tire size, front		mm	175x40	
	3.3 Tire size, rear		mm	82x90	
	3.5 Wheels, number front / rear (x = driven wheels)		n°	2 / 2	
	3.6 Track width, front		b10	mm	683
	3.7 Track width, rear		b11	mm	380
	Basic Dimensions	4.2 Mast lowered height		h1	mm
4.4 Lift height		h3	mm	1.560 2.810	
4.5 Mast extended height		h4	mm	2.078 3.340	
4.9 Height of tiller arm in drive position min. / max.		h14	mm	724 / 1.223	
4.15 Forks lowered height		h13	mm	90	
4.19 Overall length		l1	mm	1.740	
4.20 Length to face of forks		l2	m	590	
4.21 Overall width		b1/ b2	mm	779	
4.22 Forks dimensions		s/e/l	mm	55 / 180 / 1.150	
4.25 Width over forks		b5	mm	560	
4.33 Aisle width for pallets 1000 x 1200 crossways		Ast	mm	1.860	
4.34 Aisle width for pallets 800 x 1200 lengthways		Ast	mm	1.890	
4.35 Turning radius		Wa	mm	1.313	
Performance	5.2 Lifting speed with/without load		m/s	0,05 / 0,04	
	5.3 Lowering speed		m/s	0,19 / 0,13	
	5.11 Service brake		manual		
Electric Motors	6.2 Lift motor, rating S3 15%		kW	1,8	
	6.4 Battery voltage, nominal capacity K5		V/Ah	12 / 140	
	6.5 Battery weight		kg	36	
*optional					

www.viva-manipulacni-technika.cz

Tel.: +420 777 020 090

Email: info@viva-manipulacni-technika.cz